

DLS *♩* Effects™

DLS EchoTAP hookup information:

- 1) **Mono In -Mono Out** hookup: Instrument to “Input A”, use either “OutA” or “OutB” to amplifier. (**See Note 1 below concerning grounding)

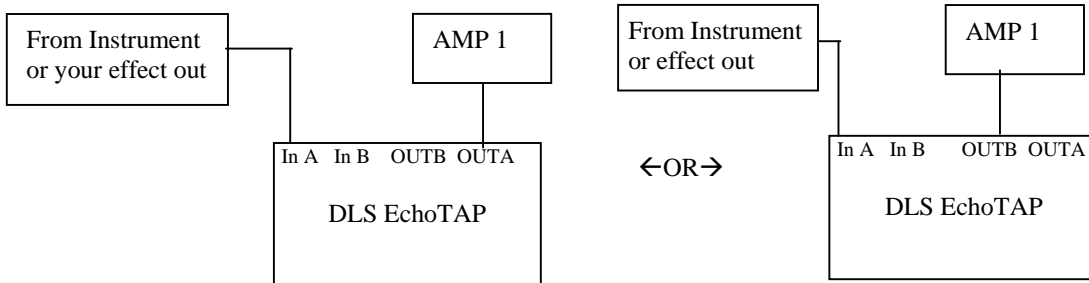

- 2) **Mono in - Stereo Out** hookup: Connect Instrument to “Input A”, connect “OutA” to amplifier #1 and “OutB” to amplifier #2. (**See Note 1 below concerning grounding)

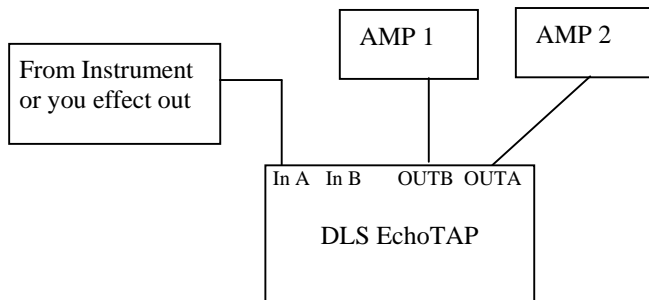

- 3) **Stereo In - Stereo Out:** Connect 1st input to “Input A”, connect “Out A” to amplifier #1, Connect 2nd input to “Input B” and “OutB” to amplifier #2. (**See Note 1 below concerning grounding)

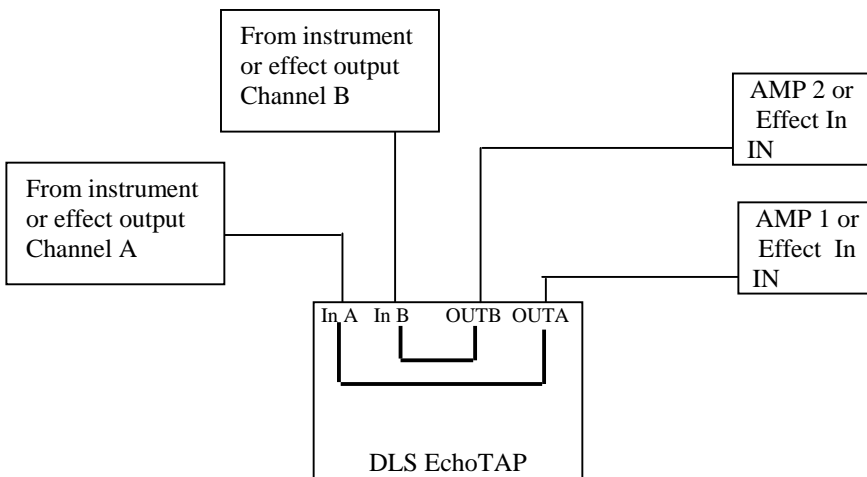

- 7) **Power for EchoTAP Delay:** Input + 9 to 13.8 vdc, 90ma minimum, any polarity 2.1mm jack. A 9vdc pedal board supply may be used provided it can supply a minimum of 90ma, the plug polarity does not matter. A 115vac, 60hz input to 9vdc output wall plug in transformer is included. (**See Note 1 below concerning grounding)

****Note 1: Warning; proper grounding and electrical hookup are required when hooking up any electrical products. In-correct grounding can cause injury or even death. If in doubt concerning grounding or electrical hookup, consult with a qualified electrician or qualified dealer.**